

Digital Lock-In Amplifiers

SR850 — DSP lock-in amplifier with graphical display



SR850 DSP Lock-In Amplifier

- **1 MHz to 102.4 kHz frequency range**
- **>100 dB dynamic reserve**
- **0.001 degree phase resolution**
- **Time constants from 10 μ s to 30 ks (up to 24 dB/oct rolloff)**
- **Auto-gain, -phase, -reserve and -offset**
- **Data logging (up to 65k samples)**
- **Smoothing, curve fitting & statistics**
- **GPIB, RS-232 and 3.5" disk drive**

The SR850 is a digital lock-in amplifier based on an innovative DSP (Digital Signal Processing) architecture. The SR850 boasts a number of significant performance advantages over traditional lock-in amplifiers—higher dynamic reserve, lower drift, lower distortion, and dramatically higher phase resolution. In addition, the CRT display and 65,536 point memory make it possible to display and process data in a variety of formats unavailable with conventional lock-ins.

Digital Precision

At the input of the SR850 is a precision 18-bit A/D converter which digitizes the input signal at 256 kHz. The A/D converter, together with a high-speed DSP chip, replace the analog demodulator (mixer), low-pass filters and DC amplifiers found in conventional lock-ins. Instead of using analog components, the SR850 is implemented by a series of precise mathematical calculations which eliminate the drift, offset, non-linearity and aging inherent in analog components. The same DSP chip digitally synthesizes the reference oscillator, providing a source with less than -80 dBc distortion, 100 mHz frequency resolution and 2 mV of amplitude resolution.

Digital Flexibility

The SR850 has a 7" CRT display which supports a large selection of display options. Data can be viewed numerically or graphically in bar graph, polar plot, and strip chart formats. With 65,536 points of memory and data acquisition rates up to

512 Hz, you are able to see exactly how your data changes in time—not just what the current output value is. After data has been acquired, the SR850 offers a variety of data reduction options, such as Savitsky-Golay smoothing, curve-fitting, and statistical analysis. A built-in 3.5" disk drive, along with standard RS-232 and GPIB interfaces, makes it easy to transfer data to your computer.

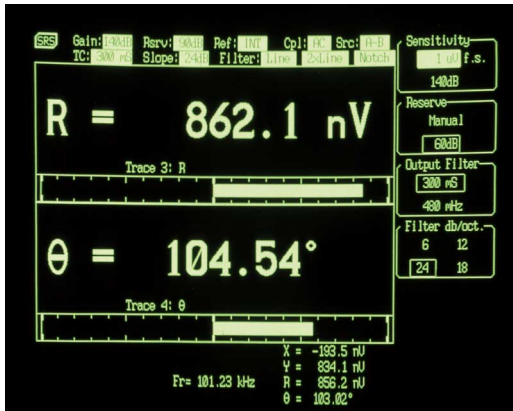

Large numeric readout with bar graph

Input Channel

The SR850 has a differential input with 6 nV/ $\sqrt{\text{Hz}}$ input noise. The input impedance is 10 M Ω , and minimum full-scale input voltage sensitivity is 2 nV. The input can also be configured for current measurements with selectable current gains of 10⁶ and 10⁸ V/A. A line filter (50 Hz or 60 Hz) and a 2 \times line filter (100 Hz or 120 Hz) are provided to eliminate line related interference. However, unlike conventional lock-in amplifiers, no tracking band-pass filter is needed at the input of the SR850. This filter is used by conventional lock-ins to increase dynamic reserve. Unfortunately, band-pass filters also introduce noise, amplitude and phase error, and drift. The DSP based design of the SR850 has such inherently large dynamic reserve that no tracking band-pass filter is needed.

Reference Channel

The reference source for the SR850 can be an externally applied sine wave or square wave, or its own digitally synthesized reference source. Because the internal reference source is synthesized from the same digital signal that is used to multiply the input, there is virtually no reference phase noise when using the internal reference. The internal reference can operate at a fixed frequency or can be swept linearly or logarithmically over the entire operating range of 1 mHz to 102.4 kHz. Harmonic detection can be performed at any integer harmonic of the reference frequency—not just the first few harmonics.

The DSP approach also offers considerable advantages when working with an external reference. The time to acquire an external reference is only 2 cycles + 5 ms (or 40 ms, whichever is greater)—about ten times faster than conventional lock-ins.

Because the SR850 uses a digital phase-shifting technique rather than analog phase-shifters, the reference phase can be adjusted with one millidegree resolution. In addition, the X and Y outputs are orthogonal to within one millidegree.

Outputs and Time Constants

The output time constants on the SR850 are implemented digitally. Low-pass-filter rolloffs of 6, 12, 18 and 24 dB/octave are available, with time constants ranging from 10 μ s to 30 ks. Below 200 Hz, the SR850 can perform synchronous filtering. Synchronous filters notch out multiples of the reference frequency—an especially useful feature at low frequencies where the proximity of the 2f component would otherwise require a long time constant for effective filtering. The SR850 makes working at low frequencies a far less time consuming task.

High Dynamic Reserve

The dynamic reserve of a lock-in amplifier at a given full-scale input voltage is the ratio (in dB) of the largest interfering signal to the full-scale input voltage. The largest interfering signal is defined as the amplitude of the largest signal at any frequency that can be applied to the input before the lock-in cannot measure a signal with its specified accuracy.

The SR850 has the highest dynamic reserve (>100 dB) of any lock-in available. In conventional lock-in amplifiers, dynamic reserve is increased at the expense of stability. Because of the digital nature of the filtering and gain process in the SR850, the ultra-high dynamic reserve is obtained without any sacrifice in stability or accuracy. In addition, the SR850's high dynamic reserve is obtained without the use of analog band-pass filters, eliminating the noise and error that such filters introduce.

Traces and Displays

Data acquired by the SR850 is stored in up to four user-defined traces. Each trace can be configured as (A \times B)/C, where A, B and C are selected from X, Y, R, θ , noise, frequency or any of the four rear-panel auxiliary inputs. Common

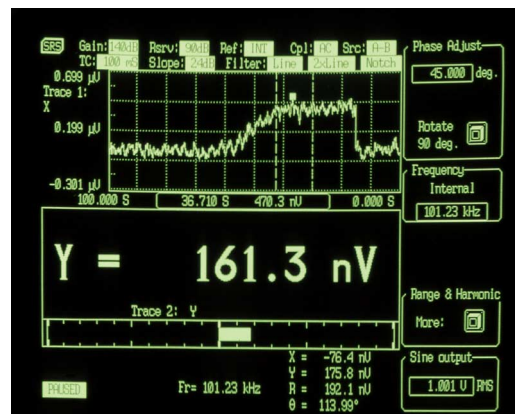

Graphical, numerical, and bar-graph display

operations, such as ratioing, can be performed in real time by defining an appropriate trace. Trace values can be displayed as a bar graph with an associated large numerical display, or as a strip chart showing the trace values as a function of time. Additionally, you can display polar plots showing the phasor



Polar plot display

formed by the in-phase and quadrature components of the signal. All displays can be easily scaled from the front panel or over the computer interfaces, and an auto-scale feature is available to quickly optimize the display. The screen can be configured as a single large display, or as two horizontally-split displays.

Convenient Auto Measurements

Common measurement parameters are available as single-key "auto" functions. The gain, phase, dynamic reserve and display scaling can all be set with a single key press. For many measurements, the instrument can be completely configured simply by using the auto functions.

Auxiliary A/Ds and D/As

Four rear-panel A/D inputs allow you to measure external signals with millivolt resolution. The measured values can be incorporated into one of the SR850's trace definitions, displayed on the front panel, or read via either computer interface. Four D/A outputs can provide either fixed output voltages or a voltage level which scans synchronously with the SR850's frequency scans. Both the A/D inputs and the D/A outputs have a ± 10 V range.

Analysis Features

The SR850's performance doesn't stop once data has been acquired—a full set of data processing features is also included. Multiple-range Savitsky-Golay smoothing can be applied to any of the trace arrays, and statistical information (mean, variance, sum) can be calculated for a selected trace region. A curve fitting routine calculates best fits to lines, exponential curves, and Gaussian curves for any portion of your data. And a trace "calculator" lets you perform a variety of simple arithmetic and trigonometric operations on trace data.

Interfaces and Hardcopies

The SR850 comes standard with RS-232 and GPIB interfaces. All instrument functions can be queried and controlled via the interfaces. For convenient debugging, characters received and sent via the interfaces can be viewed on the front panel. Several hardcopy options are available on the SR850. Screens can be dumped to a dot-matrix or LaserJet compatible printer through the standard Centronics printer interface. Displays can also be plotted on any HP-GL compatible plotter via GPIB or RS-232.

Ordering Information

SR850	DSP dual phase lock-in amplifier (w/ rack mount)
O850H	Carrying handle kit
SR550	Voltage preamplifier (100 M Ω , 3.6 nV/ $\sqrt{\text{Hz}}$)
SR552	Voltage preamplifier (100 k Ω , 1.4 nV/ $\sqrt{\text{Hz}}$)
SR554	Transformer preamplifier (0.091 nV/ $\sqrt{\text{Hz}}$)
SR540	Optical chopper



SR850 rear panel

Signal Channel

Voltage inputs	Single-ended or differential
Sensitivity	2 nV to 1 V
Current input	10^6 or 10^8 V/A
Input impedance	
Voltage input	10 M Ω + 25 pF, AC or DC coupled
Current input	1 k Ω to virtual ground
Gain accuracy	$\pm 1\%$ ($\pm 0.2\%$ typ.)
Noise (typ.)	6 nV/ $\sqrt{\text{Hz}}$ at 1 kHz 0.13 pA/ $\sqrt{\text{Hz}}$ at 1 kHz (10^6 V/A) 0.013 pA/ $\sqrt{\text{Hz}}$ at 100 Hz (10^8 V/A)
Line filters	50/60 Hz and 100/120 Hz (Q=5)
CMRR	100 dB at 10 kHz, decreasing by 6 dB/oct above 10 kHz
Dynamic reserve	>100 dB (without prefilters)

Reference Channel

Frequency range	0.001 Hz to 102.4 kHz
Reference input	TTL or sine (400 mVpp min.)
Input impedance	1 M Ω , 25 pF
Phase resolution	0.001 $^\circ$
Absolute phase error	<1 $^\circ$
Relative phase error	<0.001 $^\circ$
Orthogonality	90 $^\circ \pm 0.001^\circ$
Phase noise	
Int. reference	<0.0001 $^\circ$ rms at 1 kHz
Ext. reference	0.005 $^\circ$ rms at 1 kHz, 100 ms, 12 dB/oct
Phase drift	<0.01 $^\circ$ /C below 10 kHz, <0.1 $^\circ$ /C, 10 kHz to 100 kHz
Harmonic detection	2F, 3F, ... nF to 102.4 kHz
Acquisition time	(2 cycles + 5 ms) or 40 ms, whichever is greater

Demodulator

Stability	
Digital outputs	no drift
Analog outputs	<5 ppm/C for all dynamic reserves
Harmonic rejection	-90 dB
Offset/Expand	$\pm 100\%$ offset, expand up to 256 \times
Time constants	10 μ s to 30 ks (6, 12, 18, 24 dB/oct rolloff) Synch. filtering available below 200 Hz.

Internal Oscillator

Range	1 mHz to 102.4 kHz
Accuracy	25 ppm + 30 μ Hz
Resolution	0.01 % or 0.1 mHz (whichever is greater)
Distortion	-80 dBc ($f < 10$ kHz) -70 dBc ($f > 10$ kHz) at 1 Vrms
Amplitude	0.004 to 5 Vrms into 10 k Ω (2 mV resolution)
Output impedance	50 Ω
Amplitude accuracy	1 %
Amplitude stability	50 ppm/C
Outputs	Sine and TTL (both can be phase- locked to an external reference)
Sweeps	Linear and log

Inputs and Outputs

Interfaces	IEEE-488.2, RS-232 and Centronics interfaces standard. All instrument functions can be controlled and read through the interfaces.
X, Y outputs	± 10 V, updated at 256 ksamples/s
CH1 output	± 10 V output of X, R or Trace 1 to 4
CH2 output	± 10 V output of Y, θ or Trace 1 to 4
Aux. A/D inputs	4 BNC inputs, 1 mV res., ± 10 V
Aux. D/A outputs	4 BNC outputs, 1 mV resolution, ± 10 V (fixed or swept amplitude)
Sine out	Internal oscillator analog output
TTL out	Internal oscillator TTL output
Trigger In	TTL signal starts internal oscillator sweep or triggers instrument data taking (rates to 512 Hz).
Remote pre-amp	Provides power to the optional SR550, SR552 and SR554 preamps

Displays

Screen format	Single or dual display
Displayed quantities	Each display shows one trace. Traces are defined as A \times B/C or A \times B/C ² where A, B, C are selected from X, Y, R, θ , X-noise, Y-noise, R-noise, Aux 1 to 4 or frequency.
Display types	Large numeric readout, bar graph, polar plot and strip chart
Data buffer	64k data points. Buffer is configured as a single trace with 64k points, two traces with 32k points each, or four traces with 16k points each.
Sample rate	0.0625 to 512 Hz, external to 512 Hz

Analysis Functions

Smoothing	5, 9, 17, 21, 25 pt. (Savitsky-Golay)
Curve fitting	Linear, exponential or Gaussian
Calculator	Arithmetic, trigonometric and logarithmic calculations
Statistics	Mean and standard deviation

General

Hardcopy	Screen dumps to dot-matrix or LaserJet printers. Plots to HP-GL plotters (RS-232 or GPIB).
Disk drive	3.5" MS-DOS compatible format, 1.44 Mbyte. Storage of data and instrument setups (binary or ASCII). Screens can be saved as PCX files.
Power	60 W, 100/120/220/240 VAC, 50/60 Hz
Dimensions	17" \times 6.25" \times 19.5" (WHD)
Weight	40 lbs.
Warranty	One year parts and labor on defects in materials and workmanship

About DSP Lock-In Amplifiers

DSP lock-in amplifiers differ considerably from their analog counterparts as a glance at the block diagram below will quickly reveal. Although the front-end of both types of lock-ins contain a low-noise AC amplifier and line filters, the similarity ends there. In the SR850, the signal is filtered with a 108 kHz, 9th order, elliptical anti-aliasing filter. This filtering is crucial to ensure that the signal can be digitized by the 256 kHz, 18-bit A/D converter with no aliasing.

The A/D converter passes the digitized signal to the DSP chip. The DSP chip synthesizes a 24-bit digital reference sine wave at the reference frequency. In the internal reference case, the reference is synthesized from a high-accuracy crystal oscillator. In the external reference case, a phase-locked loop locked to the external reference serves as a source for the reference signal. The reference is multiplied by the signal in the DSP chip, which is capable of performing 16 million 24-bit \times 24-bit multiplies and additions each second. After multiplication, up to four stages of digital low-pass filtering are applied to generate time constants from 10 μ s to 30 ks, with filter rolloffs of 6, 12, 18, and 24 dB/octave.

The resulting X and Y (in-phase and quadrature) signals are used to digitally calculate the values of R and θ . The results are sent to the main system processor for display on the CRT, and passed through an 18-bit digital-to-analog converter to generate the front-panel outputs.

The same digital reference that was used to multiply the signal is converted by another 18-bit D/A converter, and is used as the SR850's internal oscillator. Thus, the internal oscillator output is actually the same signal as the reference, and there is virtually no reference phase noise when using it. Phase shifting the reference is also simple in this model, since only digital calculations are involved.

It is this digital architecture which makes possible the performance advantages found in the SR850. Comparing the diagram below with a block diagram of a conventional lock-in shows that many of the most troublesome components—noisy input prefilters, nonlinear demodulators, inaccurate analog filters, and drift-prone, high-gain DC amplifiers—have all been removed, along with their performance penalties. The resulting instrument comes closest to implementing the theoretical model of lock-in amplification.

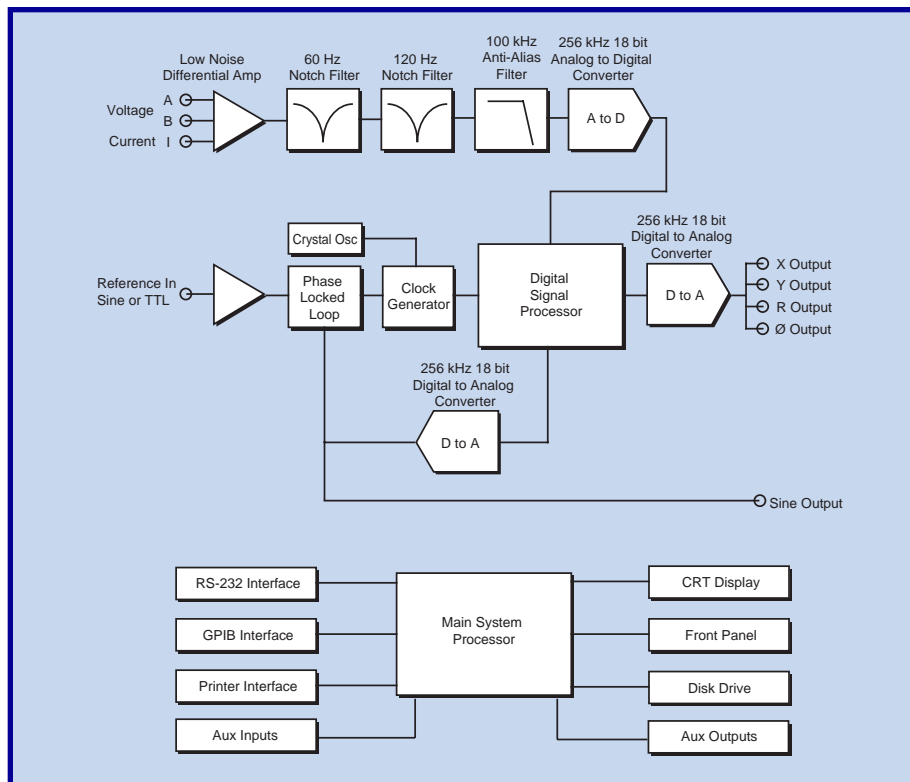

DSP Lock-In Amplifier Block Diagram