

Photon Counters

SR430 — 5 ns multichannel scaler/averager



SR430 Multichannel Scaler/Averager

- **5 ns to 10 ms bin width**
- **Count rates up to 100 MHz**
- **1k to 32k bins per record**
- **Built-in discriminator**
- **No interchannel dead time**
- **On-screen data analysis**
- **Hardcopy output to printers/plotters**
- **DOS compatible 3.5" drive**
- **GPIB and RS-232 interfaces**

The SR430 is the first multichannel scaler which combines amplifiers, discriminators, bin clocks, and data analysis in a single, integrated instrument. With its many features and its easy-to-use menu driven interface, the SR430 simplifies time-resolved photon counting experiments.

The SR430 Multichannel Scaler/Averager can be thought of as a photon counter that counts events as a function of time. A trigger starts the counter which segments photon count data into sequential time bins (up to 32k bins). The width of the bins can be set from 5 ns to 10 ms. The instrument records the number of photons that arrive in each bin.

The SR430 is useful in a variety of applications where it is necessary to count events as a function of time: LIDAR, time of flight mass spectroscopy, and fluorescence decay measurements are just a few examples.

Input and Discriminator

The SR430's analog input has a 50 Ω input impedance and an input range of ± 300 mV. The maximum input sensitivity is 10 mV, and if your input signal level is less than this, a preamplifier (like the SR445A) is recommended. The input is followed by a discriminator with a selectable slope and a threshold adjustable between ± 300 mV. A discriminator BNC output is provided at the front panel that generates a NIM level (0 to -0.7 V, active low) signal corresponding to each count.

Trigger Timing

A trigger pulse starts the data acquisition cycle. The SR430 offers a choice of bin widths ranging from 5 ns to 10.486 ms. Alternatively, an external bin clock can be provided to the SR430, allowing you to define your own bin size.

The number of bins in each record is adjustable from 1k (1024) to 32k in 1k increments. Data acquisition in the SR430 is seamless—there is no dead time between bins. Once the selected number of bins has been recorded, the SR430 either adds or subtracts the result of the current record from the accumulated bin totals.

Accumulation

The SR430 can be programmed to accumulate between one and 64k records, or set to free run. Each record can be added or subtracted from the current accumulator totals. The instrument can be set to toggle between add and subtract every N records, or an external toggle input can select the polarity of the next record. A rear-panel inhibit input allows you to selectively prevent the accumulation of any given record. The screen display is updated continuously as records are accumulated, providing a live, real-time display of the data.

Data Display

The 7" CRT screen allows flexibility in displaying your results. Between 8 and 16k bins can be displayed on the screen at any time, and horizontal and vertical zooming and scrolling features are provided. An "Auto-scale" key quickly optimizes the screen for the current data with a single key-press. A fast, responsive, on-screen cursor lets you read the maximum, minimum or mean data value from a selected range of the graph.

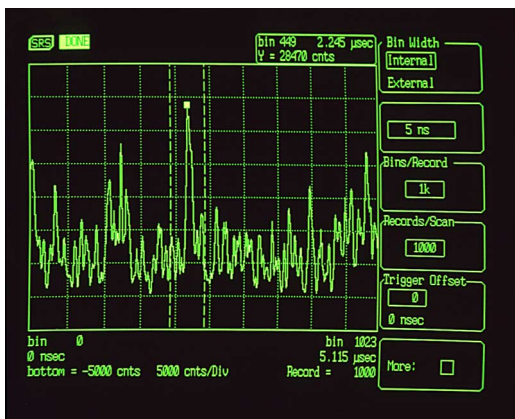

Menus and Softkeys

The SR430 is based on a simple, menu-based user interface. Each menu groups related instrument functions and defines softkeys to control those functions. The instrument settings are changed by pressing the softkeys or by turning the front-panel knob. Complete context sensitive help is provided for all

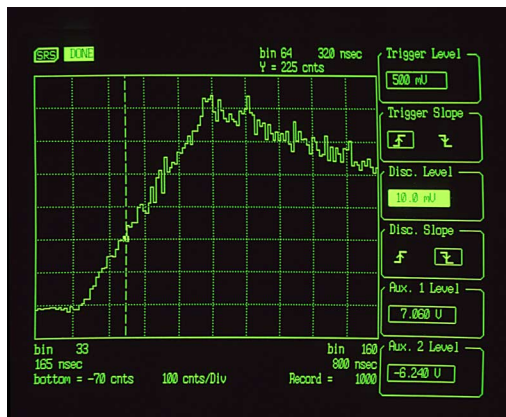

menus and softkeys. The remote command list is also provided on a help screen as an aid in programming the SR430.

Data Analysis

The SR430's extensive capabilities don't stop with data acquisition. Savitsky-Golay smoothing can be applied to any portion of the data, with selectable smoothing intervals. Gaussians, exponentials or straight lines can be fit to arbitrary regions of the display, allowing you to quickly determine decay lifetimes. Basic statistical parameters can be calculated for data regions including total number of counts, mean number of counts, and variance. Basic arithmetic operations, including addition, subtraction, multiplication, division, logs and square roots, can be applied to the current data.

Built-In Disk Drive

The SR430 has a built-in 3.5" DOS-compatible disk drive to simplify data transfer between the instrument and your computer. Both data files and settings files can be stored so you can save complete instrument setups for a variety of situations and recall them instantly.

Hardcopy Output

Hardcopy output is available from the SR430 in a variety of forms. A standard Centronics printer port lets you dump the screen to dot-matrix or LaserJet compatible printers at any time. Additionally, the SR430 can plot its display on any HP-GL compatible plotter via the RS-232 or GPIB interface.

Complete Programmability

Both RS-232 and GPIB interfaces are standard on the SR430. All instrument settings and functions can be read and set via the interfaces. A complete list of all characters received and transmitted over the interfaces can be displayed on the CRT screen—an invaluable aid when debugging your programs. Numerous modes are available for downloading the count data to your computer including ASCII transfer, binary transfer, and a fast binary dump mode which transfers data continuously over the GPIB interface as it is being acquired.

Signal Input

Bandwidth	DC to 250 MHz
Input impedance	50 Ω
Linear range	±300 mV (at input)
Input protection	±5 VDC, 50 V for 1 μs
Overload recovery	5 ns for <10 μs duration overload

Discriminator

Discriminator range	-300 mV to +300 mV
Resolution	0.2 mV
Slope	Positive or negative
Accuracy	2 mV + 1 %
Min. pulse amplitude	10 mV
Pulse-pair resolution	10 ns (typ.)
Discriminator output	NIM level into 50 Ω. (There is a 20 ns insertion delay from the signal input to the discriminator output.)

Trigger Input

Impedance	10 kΩ
Threshold	-2.000 V to +2.000 V in 1 mV steps
Slope	Rising or falling
Protection	15 VDC, 100 V for 1 μs

Internal Time Bins

Bin width	5 ns, 40 ns, 80 ns, 160 ns, 320 ns, 640 ns, 1.28 μs, 2.56 μs,...10.486 ms (10 ns and 20 ns are not available)
Accuracy	1 ns + 20 ppm of bin width
Jitter (rms)	100 ps + 10 ppm of delay from SYNC/BUSY output (bins are synchronous with SYNC/BUSY output)
Indeterminacy	2.5 ns with respect to trigger input
Insertion delay	45 ns from trigger to first bin. Rising edge of SYNC/BUSY output occurs at beginning of first bin. Signal pulses arriving 25 ns after the trigger will be counted in the first bin.

Externally Clocked Time Bins

EXT BIN CLK input	Rising edge triggers next time bin
Maximum frequency	4 MHz (250 ns minimum bin width)
Minimum time high	100 ns
Minimum time low	100 ns
Insertion delay	Rising edge of SYNC/BUSY output occurs at first rising edge of EXT BIN CLK after trigger. The beginning of the first bin occurs at the same time.

Counters/Accumulation

Bins per record	1k to 16k in 1k increments (1024 to 32,704 including trigger offset)
-----------------	--

Max. count rate	100 MHz
Max. count	32,767 per bin per trigger
Records/accumulation	1 to 64k (or free run)
Max. accumulation	32,767 per bin in Add mode, ±16,383 per bin in Toggle or External mode
Add/subtract	Records may be added or toggled (add/subtract on alternating triggers). External subtract input may also control the toggle.

Trigger Rate

Minimum trigger time	$T_p = (\# \text{ of bins} \times \text{bin width}) + (\# \text{ of bins} \times 250 \text{ ns}) + 150 \mu\text{s}$ SYNC/BUSY output is high for T_p after each trigger. When SYNC/BUSY returns low, the next record may be triggered. Triggers received while SYNC/BUSY is high are ignored.
----------------------	--

Outputs

DISC	NIM level into 50 Ω. Low whenever signal input exceeds discriminator level with the correct slope.
SYNC/BUSY	TTL level. Rising edge is synchronous with first time bin of each record. Remains high until re-armed for next trigger.
BIN CLK	NIM level into 50 Ω. Each transition is a bin boundary. Active only while a record is being acquired. Timing skew relative to DISC out is <2 ns.
TOGGLE	TTL level. Indicates whether the next record will be added to or subtracted from the accumulation. (Internal toggle mode)
TEST	50 MHz NIM output into 50 Ω
AUX1, AUX2	(General purpose analog outputs)
Full scale	±10 V
Resolution	5 mV
Output current	10 mA
Output impedance	<1 Ω
Accuracy	0.1 % + 10 mV

Inputs

SIGNAL	Analog 50 Ω input
TRIGGER	10 kΩ input
BIN CLK INPUT	TTL input (Rising edge triggers next time bin)
ACC. INHIBIT	TTL input, sampled each trigger. If high, causes the current record to be ignored (not accumulated)
SUBTRACT	TTL input, sampled each trigger. If high, causes the current record to be subtracted from the accumulation (in external toggle mode).

General

Interfaces	IEEE-488.2, RS-232, and Centronics printer interfaces are standard. All instrument functions can be controlled and read through the interfaces.
Data transfer	16k bins in 500 ms
Hardcopy	Screen dumps to Epson compatible dot-matrix or HP LaserJet printers. Plots to HP-GL compatible plotters (serial or IEEE-488.2).
Disk	3.5" DOS compatible format 720k byte capacity
Power	Storage of data and setups 60 W, 100/120/220/240 VAC, 50/60 Hz
Dimensions	17" × 6.25" × 16.5" (WHD)
Weight	30 lbs.
Warranty	One year parts and labor on defects in materials and workmanship

Ordering Information

SR430	Multichannel scaler/averager with rack mount kit
SR445A	350 MHz preamplifier
O430H	Carrying handle



SR430 rear panel

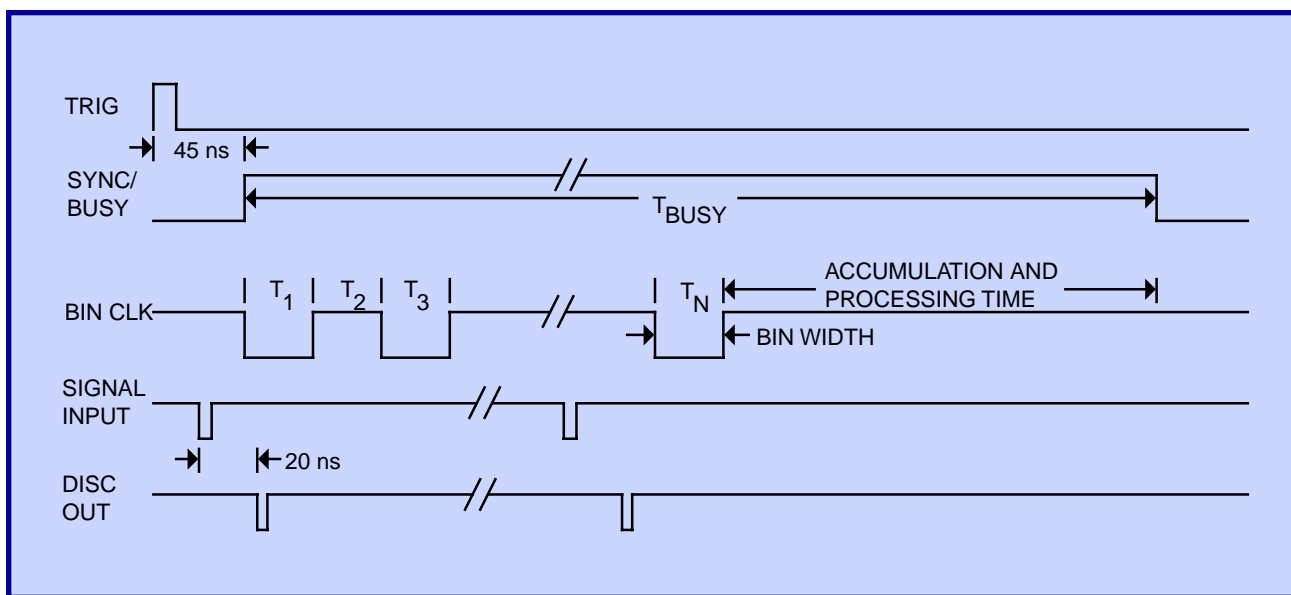

SR430 timing diagram

Fluorescence Decay of Ruby

This experiment is typical of time resolved photon counting experiments. A pulsed light source is used to pump atoms to an excited state. Fluorescent decay from the excited state is observed, allowing the lifetime of the upper state to be measured.

The energy level diagram of ruby is shown below. There are absorption bands around 400 nm and 550 nm. The Cr⁺⁺⁺ ions, which absorb light at these wavelengths, decay in about 50 ns to the upper state of the well known laser transition. This state has a lifetime of about 3.5 ms, and decays to the ground state by emitting a photon at 694.3 nm.

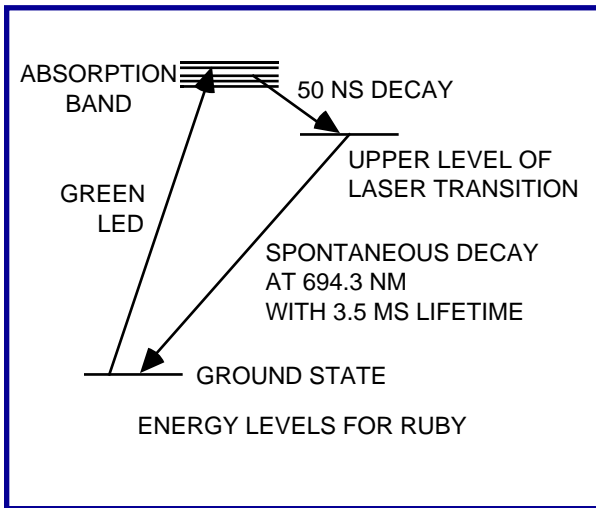

The absorption band at 550 nm overlaps the emission line of a green LED. In this example experiment, a pulsed green LED is used to quickly populate the excited state, and decays from the excited state are seen through a band pass interference filter centered on ruby's 694.3 nm emission line.

Apparatus

The experimental set-up is shown below. The green LED is glued to the edge of a 1 cm diameter, 3 mm thick, ruby disk. The ruby disk is viewed through the band-pass interference filter by a Hamamatsu R928 PMT. This side-on PMT was selected for its high gain, fast rise time, and good red sensitivity.

Experiment Setup

The phototube base uses a tapered voltage divider with about 3x the normal interstage voltage between the photocathode and the first dynode. This helps to narrow the pulse height spectrum for single photon events. The lower dynodes are bypassed, and 100 Ω resistors are used between the dynodes and their bypass capacitors to reduce ringing in the anode signal. A snubber network, consisting of a ten inch piece of RG174 terminated into 20 Ω, is used to further reduce anode ringing and reduce the fall time of the output current pulse.

Operation

The PMT is operated at the maximum rated high voltage (1250 VDC). The output pulses have a mean amplitude of 20 mV into 50 Ω. To increase the pulse height to 100 mV, one amplifier in the SR445A preamp provides a gain of 5 with a 350 MHz bandwidth. The discriminator threshold is set to 20 mV. When viewed with a 300 MHz oscilloscope, it is

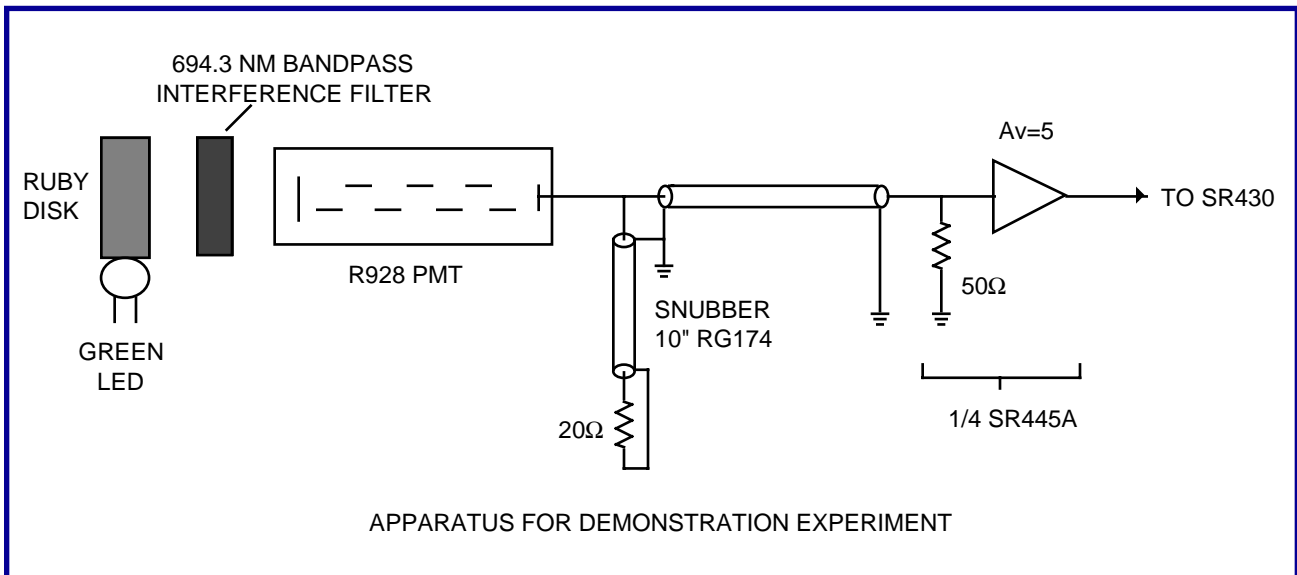

apparent that this threshold setting will count the majority of output pulses but will not count anode rings or amplifier noise.

The green LED is flashed at a 40 Hz rate and has a pulse width of about 1 ms. During this time, population integrates in the upper level of the laser transition. Spontaneous decays from the upper level are counted by the SR430 Multichannel Scaler/Averager.

Instrument Configuration

The multichannel scaler is triggered by the same pulse which flashes the LED. The bin width is 20.48 μs, and the record length is 1k bins. The records per accumulation is set to 100. Thus, each record takes approximately 21 ms of real time to acquire which is sufficient to measure the 3.5 ms lifetime of the excited state. The pulse rate of 40 Hz will not generate rate errors. A summary of the SR430 setup parameters is shown below.

Data Acquisition

After the SR430 Levels and Mode menus have been setup, data acquisition may begin. Pressing the [START] key starts the first record. Data accumulates on the screen until all 100 records have been acquired. When data acquisition is complete, the math menu may be used to fit an exponential curve to the data to measure the lifetime directly. Finally, the data curve is printed or plotted and stored to disk. A picture of an actual decay curve obtained with an SR430 is shown to the right, along with the exponential fit to the data. The decay time measured by the SR430 is 3.5 ms—quite close to the actual value.

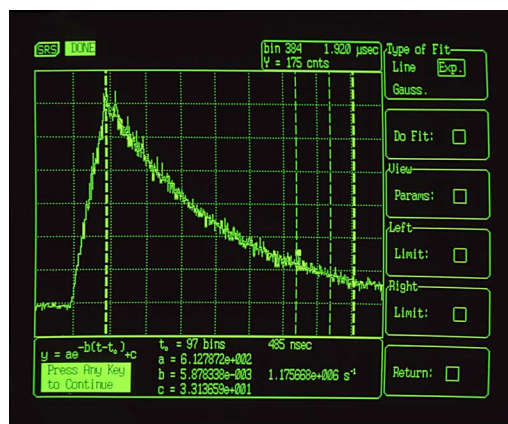

Fluorescence decay of ruby

SR430 Configuration for Ruby Experiment		
Levels		
Trigger Level	+1.000 V	Trigger threshold set to +1.000V
Trigger Slope	RISE	Trigger on rising edge of LED trigger
Disc Level	-20.0 mV	Disc threshold set to -20.0 mV
Disc Slope	FALL	Discriminate negative pulses
Mode		
Bin Clk Source	Internal	Internal bin time base
Bin Width	20.48 μs	20.48 μs bins
Bins/Record	1k	1024 bins/record
Records/Scan	100	Accumulate 100 records
Trigger Offset	0	Start data at bin #0
Accumulate Mode	Add	Add all records to accumulation