

Small Instrumentation Modules

SIM925 — Octal four-wire multiplexer

- **Eight input channels**
- **Four-pole relay switching**
- **Selectable buffer for V-sense lines**
- **Rear-panel bypass for unlimited daisy-chaining**



— **SIM925 Octal Four-Wire Multiplexer**

The SIM925 is an eight input channel, four-wire multiplexer for low-level signal applications. Kelvin-lead measurements are supported with optional buffering of the two sense leads. The buffer can be switched out to form a simple relay-based, 4-pole/8-throw switch. Multiple modules may be cascaded, allowing unlimited networking possibilities.

The digital control circuitry in the SIM925 is designed with a special clock-stopping architecture in which the microcontroller is turned on only when switch settings are being changed. This guarantees that no digital noise contaminates low-level analog signals.

Settings may be changed from the front panel or through the remote interface. The multiplexer settings can also be queried. If armed, the module generates a status signal to alert the user of an overload condition. The SIM925 can be operated outside the SIM mainframe by powering it with its required DC voltages.

The SIM925 may be used directly with the SIM921 AC Resistance Bridge, SIM922A Diode Monitor, or SIM923A RTD Monitor to read many temperature sensors. It may also be used to route multiple signal sources to a lock-in amplifier, thus automating signal recovery tasks.

Input channels	8 (plus 1 bypass channel)
Wires per channel	4
Series resistance	2.0 Ω (max.)
Isolation resistance	>10 G Ω (typ.)
Input capacitance	<60 pF on selected channel, between any 2 leads or ground. <25 pF on selected to unselected channel, any 2 leads. <25 pF on unselected channels.
Max. switching capacity	10 mA @ 10 VDC
Thermal EMF	<10 μ V (typ.)
Switching order	Break-before-make (default) Make-before-break (remote interface only)
Switching speed	50 ms max. (break-before-make)
Active buffer	
Bandwidth	1 MHz (typ.)
Input noise	30 nV/ $\sqrt{\text{Hz}}$ @ 10 Hz 16 nV/ $\sqrt{\text{Hz}}$ @ 1 kHz
Bias current	5 pA (typ.)
Input overload	\pm 1.0 V
Operating temperature	0 $^{\circ}$ C to 40 $^{\circ}$ C, non-condensing
Interface	Serial via SIM interface
Connectors	
Input channels	DB37 (female, front panel)
Common	DB9 (male, rear panel)
Bypass	DB9 (female, rear panel)
SIM	DB15 (male) SIM interface
Power	\pm 15 VDC (10 mA), +5 VDC (50 mA)
Dimensions	1.5" \times 3.6" \times 7.0" (WHD)
Weight	1.5 lbs.
Warranty	One year parts and labor on defects in materials and workmanship

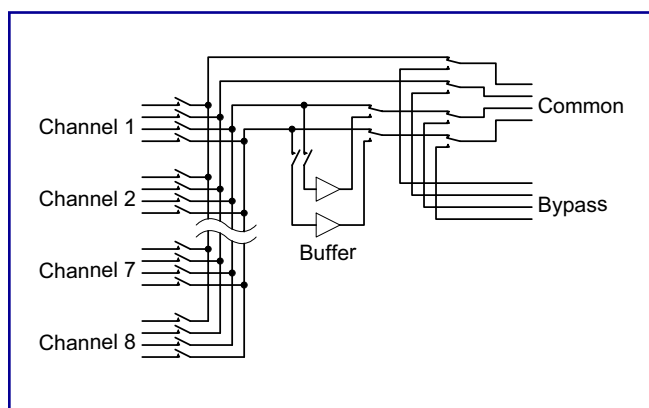
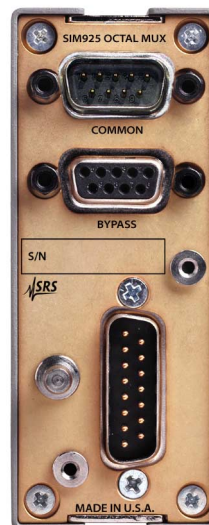

SIM925 block diagram

Ordering Information

SIM925 Octal four-wire multiplexer