

High Voltage Power Supplies

PS300 Series — 1.25 kV (PS310), 2.5 kV (PS325), 5 kV (PS350) power supplies



PS300 Series High Voltage Power Supplies

- **1.25 kV, 2.5 kV, 5 kV supplies**
- **25 W output power**
- **1 volt resolution**
- **0.001 % regulation, 0.05 % accuracy**
- **Dual polarity**
- **Programmable limits and trips**
- **0.0015 % ripple**
- **GPIB interface (opt.)**

The PS300 series of high-voltage DC power supplies consists of three efficient, microprocessor-controlled, switching power supplies capable of delivering 25 watts of output power at voltages up to 5 kV. All models have 0.001 % regulation and 0.05 % accuracy, and the output voltage can be adjusted with one volt resolution over the entire operating range.

All PS300 series supplies have rear-panel SHV (Kings type 1704-1 or equivalent) connectors. Optional cables allow connection with standard high-voltage connectors (SHV or MHV). A three-position, high-voltage enable switch on the front panel prevents the high voltage from being turned on under computer control unless the switch has been manually armed. A highly visible red LED always indicates when the high voltage is on. Convenient front-panel LED displays indicate both the voltage and current delivered to the load at all times.

Limits and Trips

The PS300 series power supplies have an adjustable voltage limit which prevents the high voltage from being inadvertently set above a safe level. An independent current limit lowers the voltage setting until the current drawn by the load does not exceed the limit setting. Additionally, a current trip may be set which turns off the high voltage when the current limit is exceeded. After a trip, the unit can be configured to either attempt to turn the high voltage back on, or to leave it off until a manual reset.

Adjustable Polarity

The output polarity of the PS300 series power supplies is set with a rear-panel switch. The polarity cannot be controlled via the computer interface and can only be changed while the unit is off. Output polarity is always displayed on the front panel with the voltage level.

Voltage and Current Monitors

Two rear-panel BNC connectors provide voltage and current monitoring capabilities. A 0 V to 10 V output corresponds to 0 % to 100 % of full scale. These outputs are capable of driving 10 mA and have a 1 Ω output impedance.

The voltage monitor output can also be configured as a voltage control input. In this mode, a 0 V to 10 V signal applied at the input will cause the output high voltage to vary between 0 % and 100 % of full scale. The output is updated at a rate of 16 Hz. Additionally, the bandwidth of the voltage control input is limited by the overall slew rate specification of the instrument (0 % to 100 % of full scale in less than 0.3 s under full load).

Stored Settings

All instrument settings are stored in non-volatile memory so that the instrument will remember its previous state when powered up. For safety, the high voltage is always initially turned off. Up to nine complete instrument configurations, including limit and trip settings, can be stored in memory.

Optional GPIB Interface

An optional GPIB interface allows control of all instrument functions except output polarity. The required common commands of the IEEE-488.2 standard are supported. The power supply can be configured to generate service requests (SRQ) in the event of limit or trip conditions.

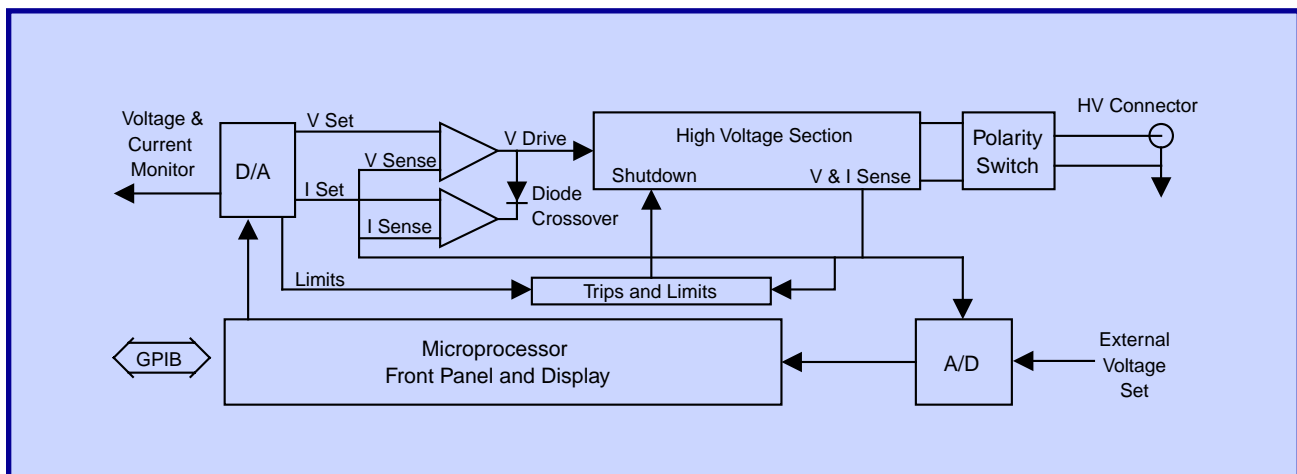

PS300 Series Block Diagram

A high voltage (HV) section converts low drive voltage into high voltage (all high voltage components in the HV section are shielded). The output voltage (V) and current (I) are sensed and fed back to high-gain compensation circuitry where they are compared to the programmed values. The compensation circuit controls the output voltage by setting the level of the drive voltage. A diode crossover allows control of both voltage and current.

Programmed values for the output, limits and trips are set by the microprocessor through a D/A converter. Fast-acting limit circuits check the sensed voltage and current. These work independently of the microprocessor to react quickly in protecting both the supply and load.

The processor reads the sensed values via an A/D converter and displays them on the front panel. The A/D also reads the External Voltage Set (when enabled).

Model	Output Voltage (+/-)	Maximum Current
PS310	12 VDC to 1.25 kV	20 mA
PS325	25 VDC to 2.50 kV	10 mA
PS350	50 VDC to 5.00 kV	5 mA

Voltage Output

Voltage set accuracy	0.01 % + 0.05 % of full scale
Volt. display accuracy	V_{set} accuracy ± 1 V, typ. (± 2 V, max.)
Voltage resolution	1 V (set and display)
Voltage resettability	1 V
Voltage limit range	0 to 100 % of full scale
Voltage regulation	0.001 % for ± 10 % line change 0.005 % for 100 % load change Specifications apply for >0.5 % (full load) to >1 % (no load) of full-scale voltage.
Output ripple (rms)	<0.0015 % of full scale (typ.) <0.002 % of full scale (max.)
Current limit range	0 to 105 % of full scale
Trip current	10 μ A (min.)
Trip response time	<10 μ s
Current set accuracy	0.01 % + 0.05 % of full scale
Current resolution	10 μ A (PS310 and PS325) 1 μ A (PS350)
Current display accuracy	± 10 μ A (typ.), ± 20 μ A (max.) (PS310 and PS325) ± 1 μ A (typ.), ± 2 μ A (max.) (PS350)
Stability	0.01 % per hr., <0.03 % per 8 hrs.
Temperature drift	50 ppm/ $^{\circ}$ C, 0 to 50 $^{\circ}$ C (typ.)
Protection	Arc and short circuit protected (Programmable voltage limit, current limit, and current trip)
Recovery time	12 ms for 40 % step change in load current (typ.)
Discharge time	<6 s (to <1 % of full-scale voltage with no load, typ.)

Monitor Output

Output scale	0 to +10 V for 0 to full-scale output regardless of polarity
Current rating	10 mA (max.)
Output impedance	<1 Ω
Accuracy	0.2 % of full scale
Update rate	8 Hz

External Voltage Set

Input scale	0 to +10 V for 0 to full-scale output regardless of polarity
Input impedance	1 M Ω
Accuracy	0.2 % of full scale
Update rate	16 Hz
Output slew rate	<0.3 s for 0 to full scale under full load

Mechanical

HV connector	SHV male (Kings type 1704-1)
Mating connector	SHV female (Kings type 1705-14)
Dimensions	8.1" \times 3.5" \times 16" (WHD)
Weight	8 lbs.
Power	50 W, 100/120/220/240 VAC, 50/60 Hz
Warranty	One year parts and labor on defects in materials or workmanship



PS350 rear panel (with opt. 01)

Ordering Information

PS310	1.25 kV HV power supply
PS325	2.5 kV HV power supply
PS350	5.0 kV HV power supply
Option 01	GPIB computer interface
O2D	Double rack mount kit
O2S	Single rack mount kit
O3A	SHV to SHV cable, 10 ft.
O3B	SHV to MHV cable, 10 ft.